

Tailpipe Emissions to Fuels Quality Standard

Atsushi Kameoka
Japan Automobile Research Institute

Contents

1. Emission/Fuel Regulations of Japan, U.S. and Europe
2. Effect of Gasoline Fuel Quality
3. Effect of Diesel Fuel Quality

Emission/Fuel Regulations of Japan, U.S. and Europe for Gasoline

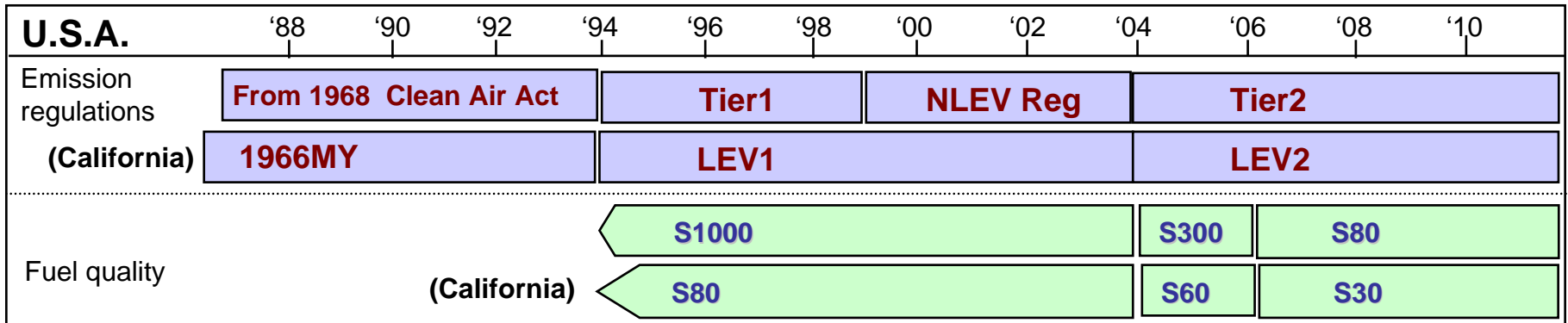
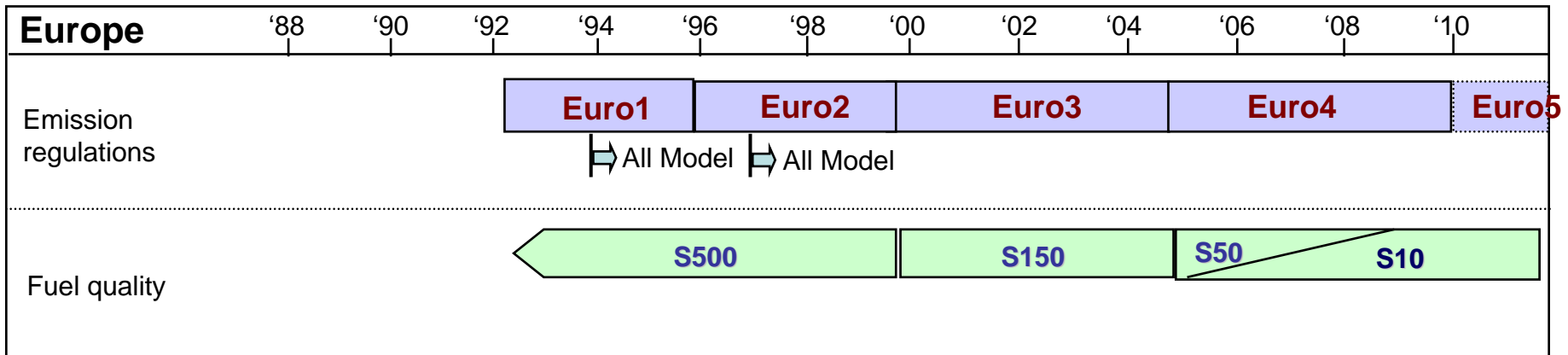
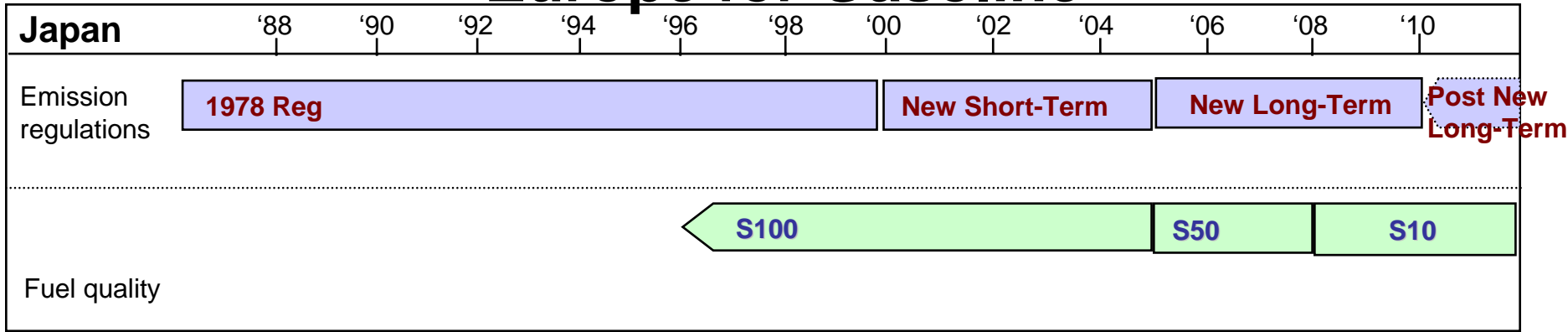

Emission/Fuel Regulations of Japan, U.S. and Europe for Diesel

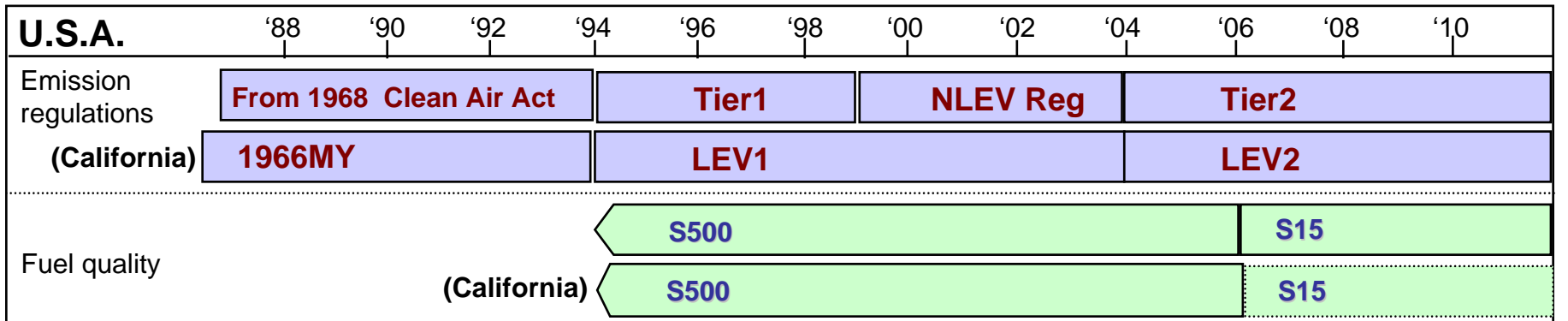
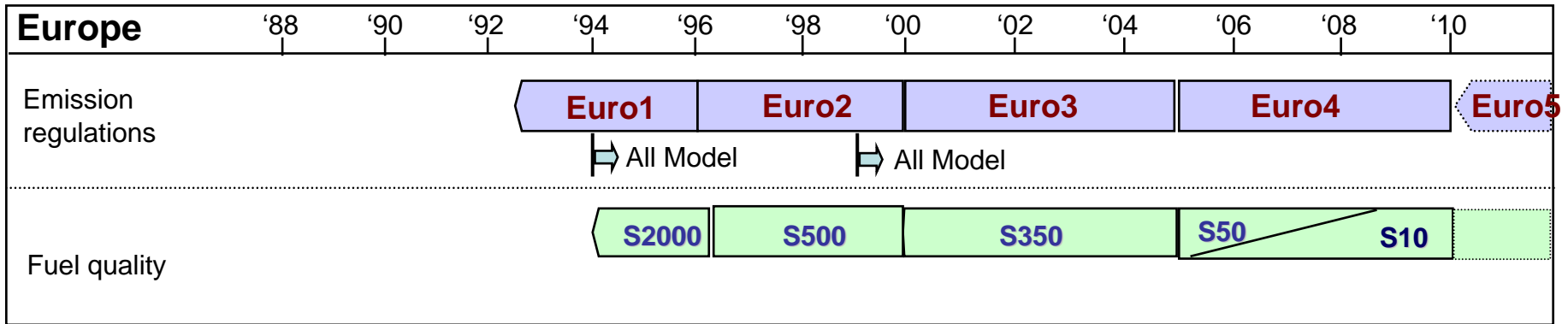
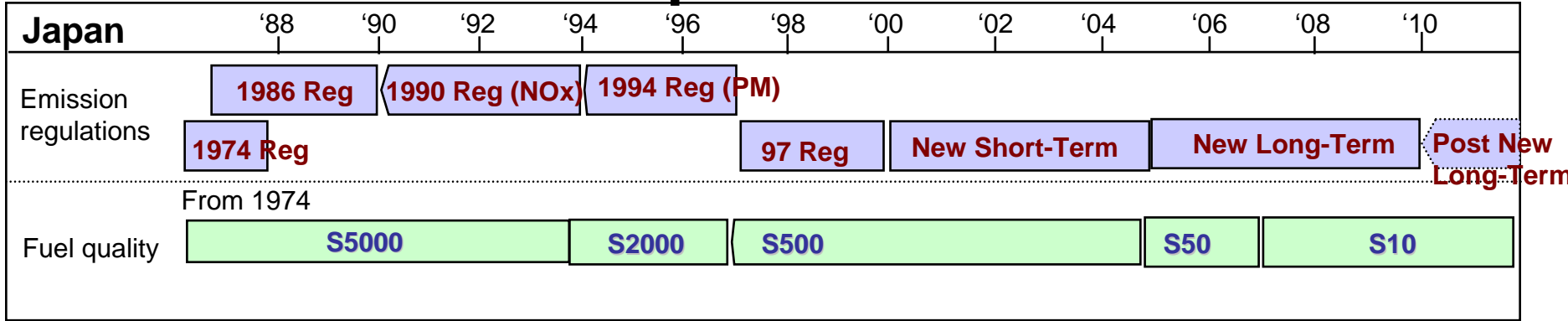

Contents

1. Emission/Fuel Regulations of Japan, U.S. and Europe
2. Effect of Gasoline Fuel Quality
3. Effect of Diesel Fuel Quality

Low Emission Technologies for Gasoline Engine

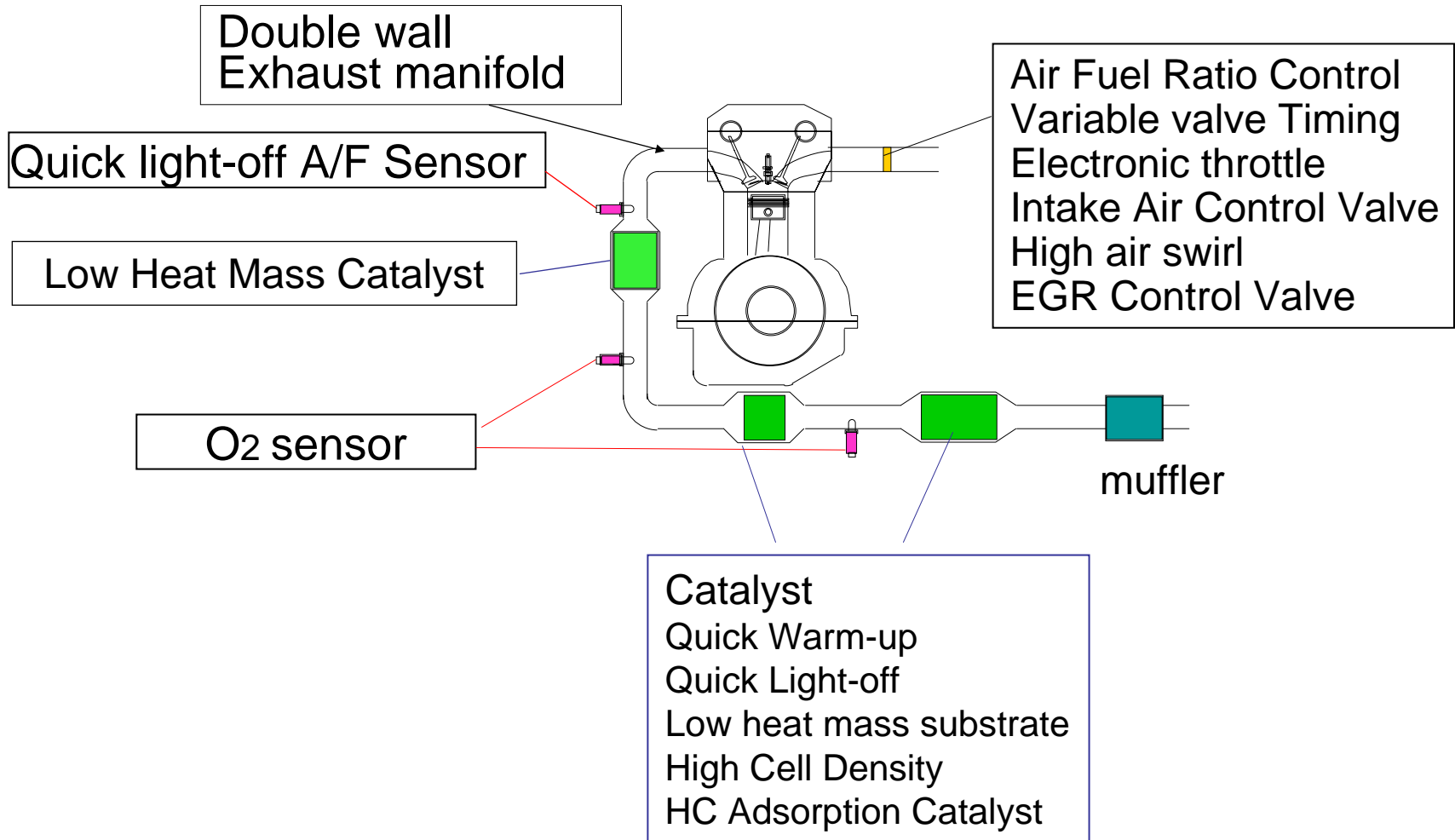

Effects of Sulfur in Gasoline on Exhaust Emissions

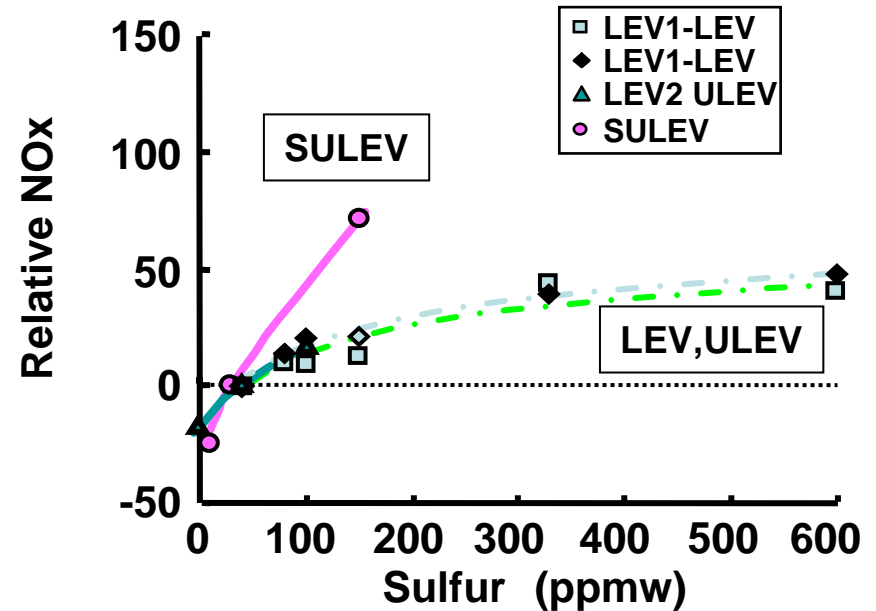
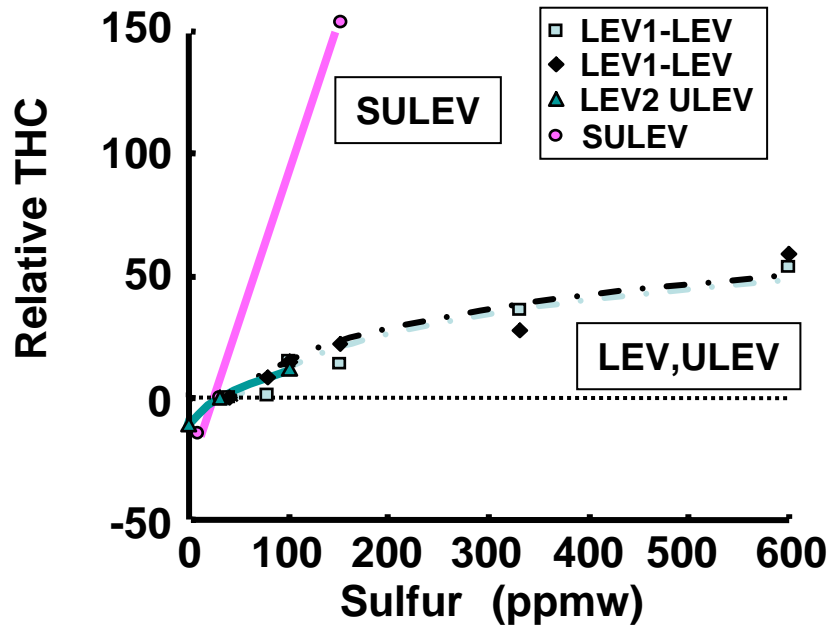

Source : SAE2000-01-2019

SULEV : Super Ultra Low Emission Vehicle, ULEV : Ultra Low Emission Vehicle, LEV : Low Emission Vehicle

Effects of Fuel Sulfur on NSR Catalyst Performance

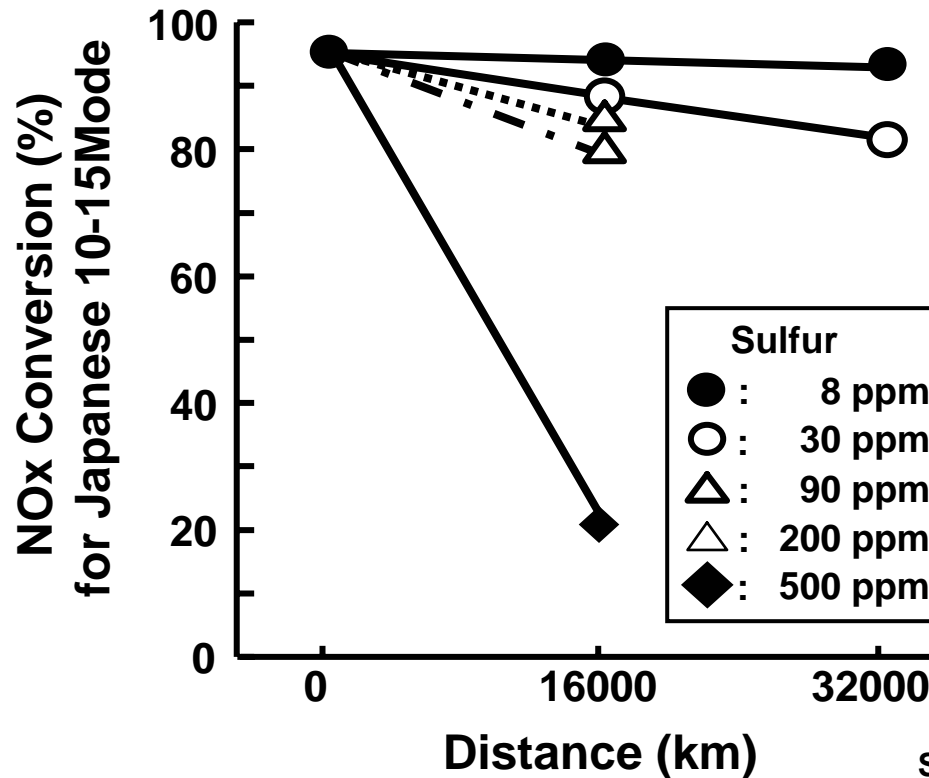

Source : SAE2000-01-2019

•Fuel sulfur has significant impact on NOx catalyst performance.

Effects of Sulfur in Gasoline on Catalyst Performance

NSR Catalyst (Lean burn)

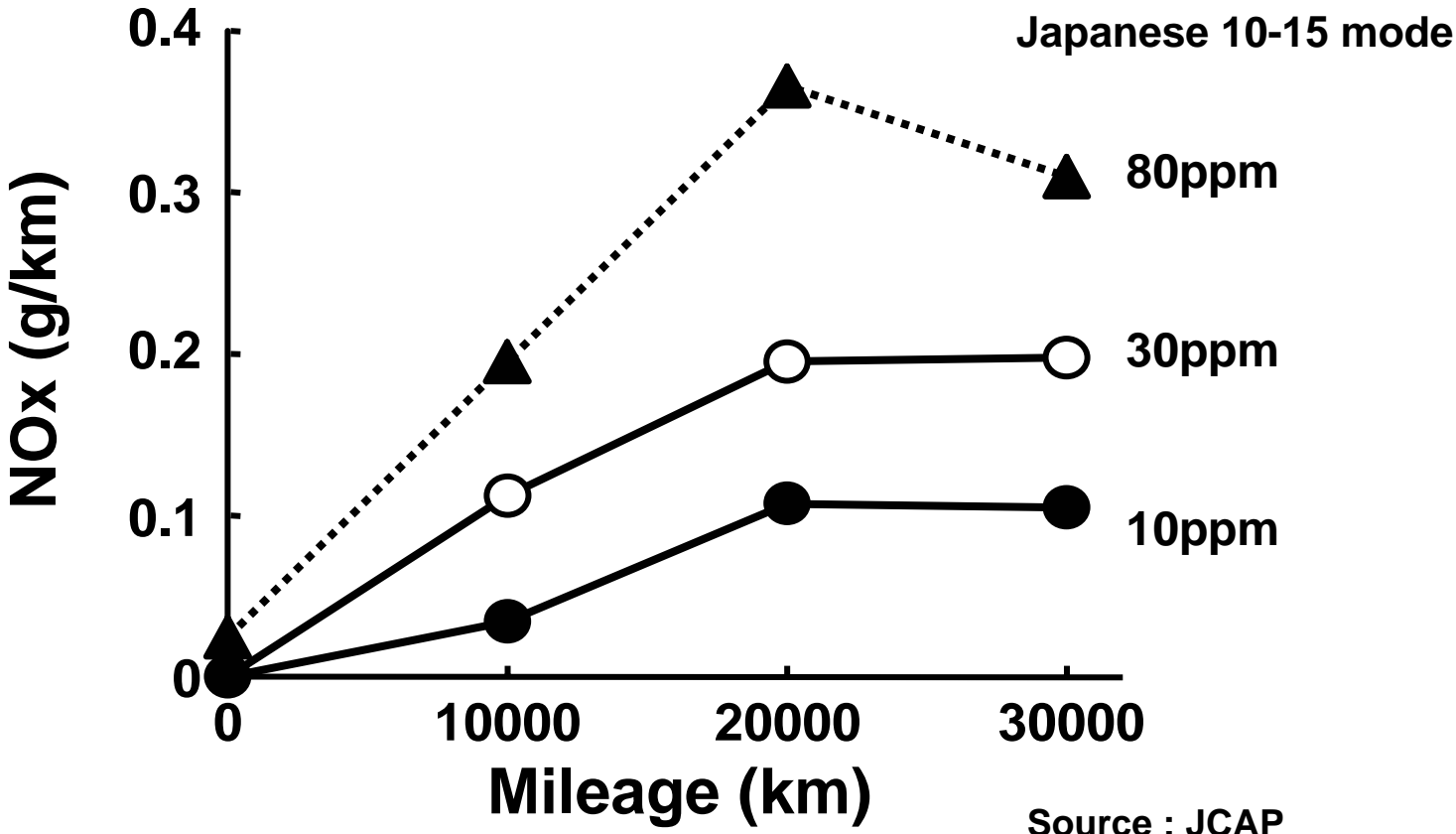

Effects of Distillation Temperature on Exhaust Emissions

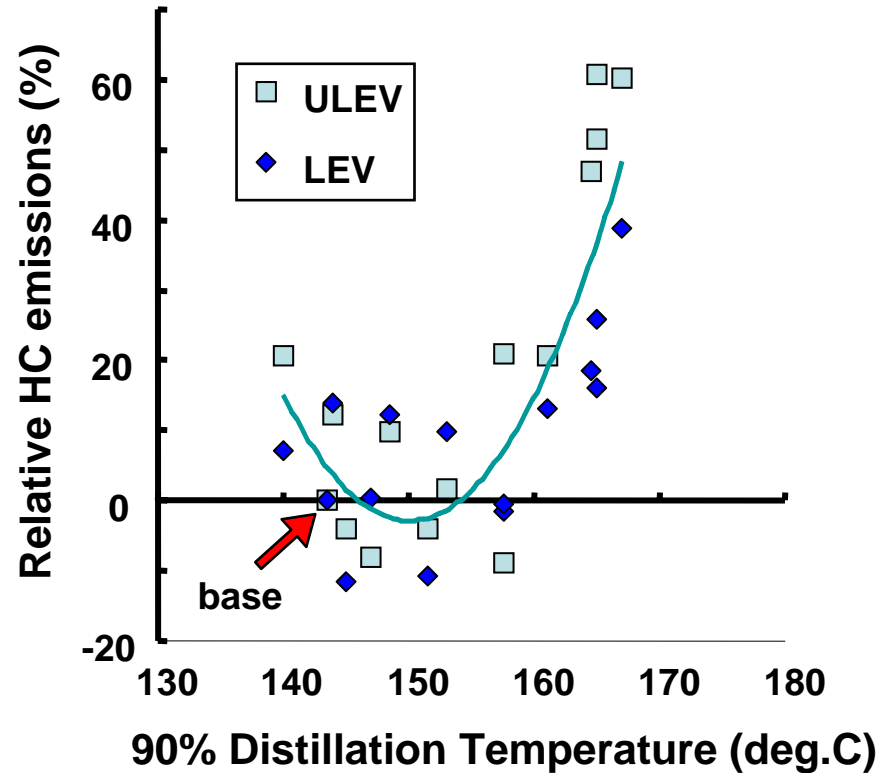
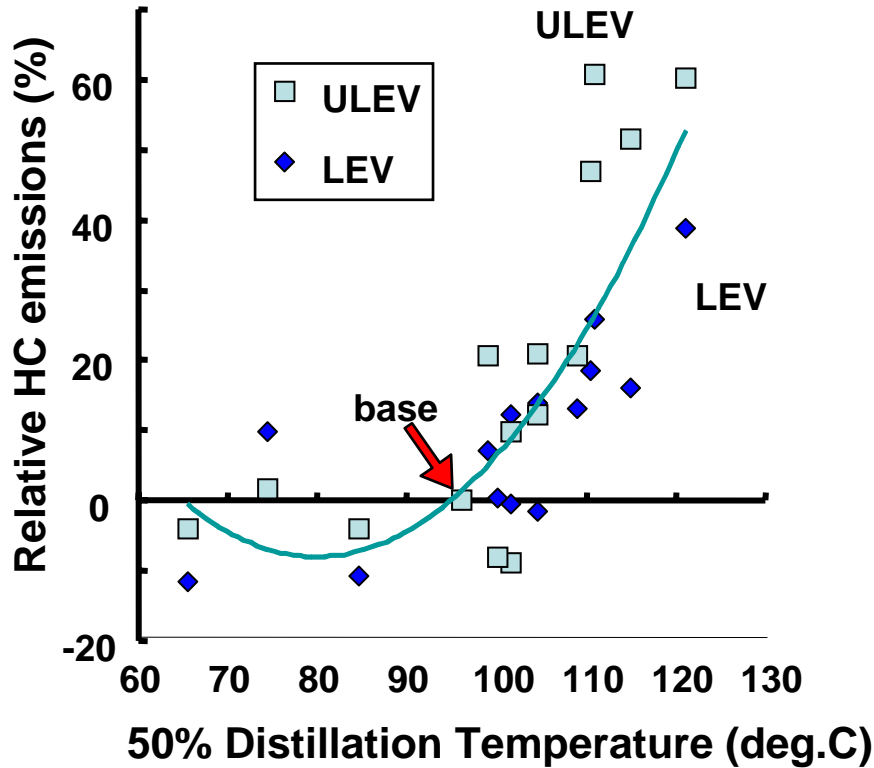

Source : SAE2000-01-2019

ULEV : Ultra Low Emission Vehicle, LEV : Low Emission Vehicle

Effects of Fuel Properties on Emissions

Gasoline

Properties \ Emissions	HC	CO	NOx	Toxics
T50 ↓	↘		→	
T90 ↓	↘			↘
Aromatics ↓	↘	↘	✕	↘
Olefins ↓			↘	
Sulfur ↓	↘	↘	↘	↘
Oxygenates ↑	↘	↘		
Detergent ↑	↘	↘	↘	

Contents

1. Emission/Fuel Regulations of Japan, U.S. and Europe
2. Effect of Gasoline Fuel Quality
3. Effect of Diesel Fuel Quality

Emission Reduction Technology

- Injection Timing Retard
- Combustion Improvement
- Inter-Cooler Turbo Charger
- EGR Cooler
- EGR(Exhaust Gas Recirculation)
- DPF(Diesel Particulate Filter)
- Oxidation Catalyst
- LNT(Lean NOx Trap)
- NSR(NOx Storage Reduction)
- SCR(Selective Catalytic Reduction)

Effects of Diesel Fuel Properties on PM

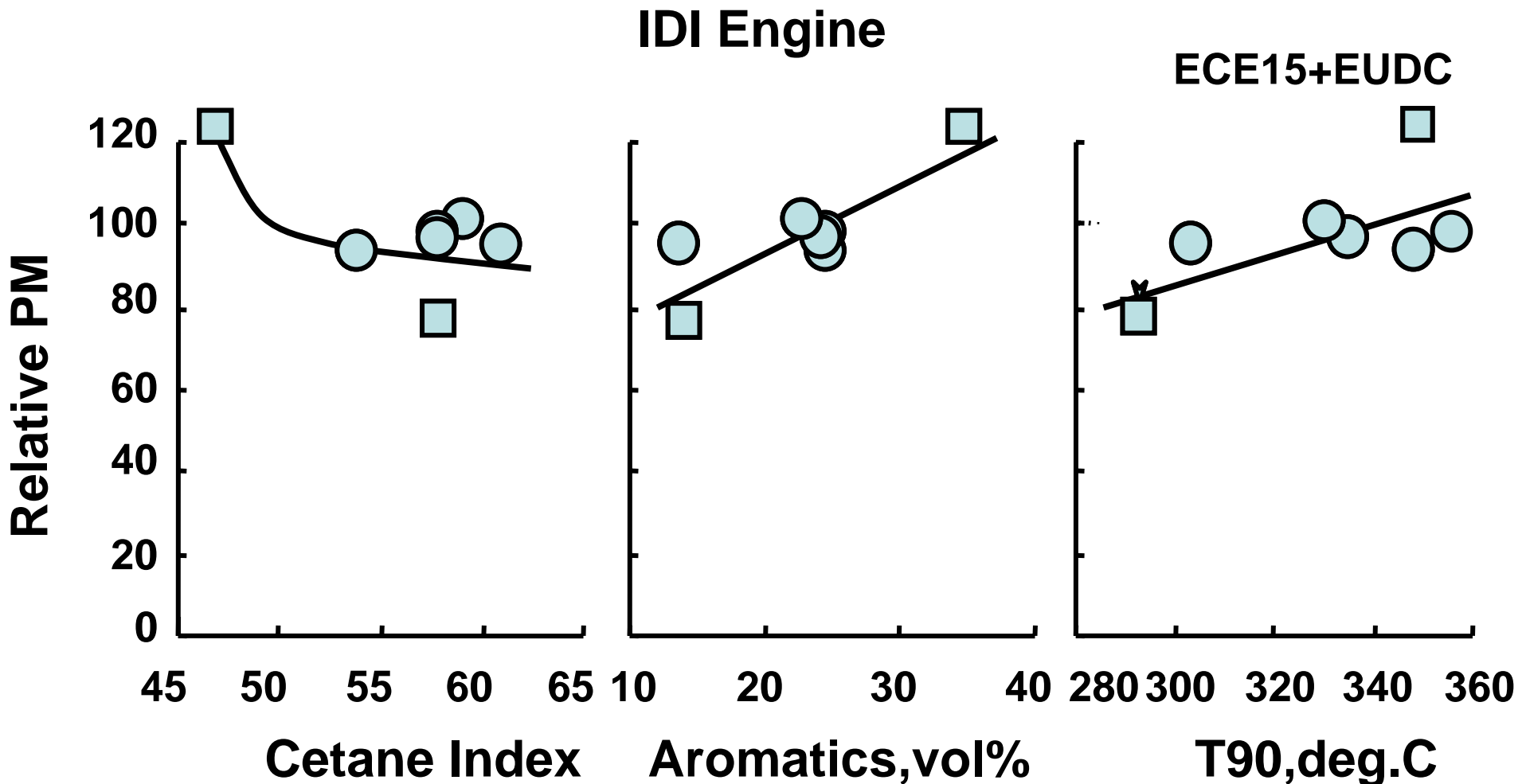

Effects of Sulfur in Diesel Fuel on NOx (NOx Catalyst System)

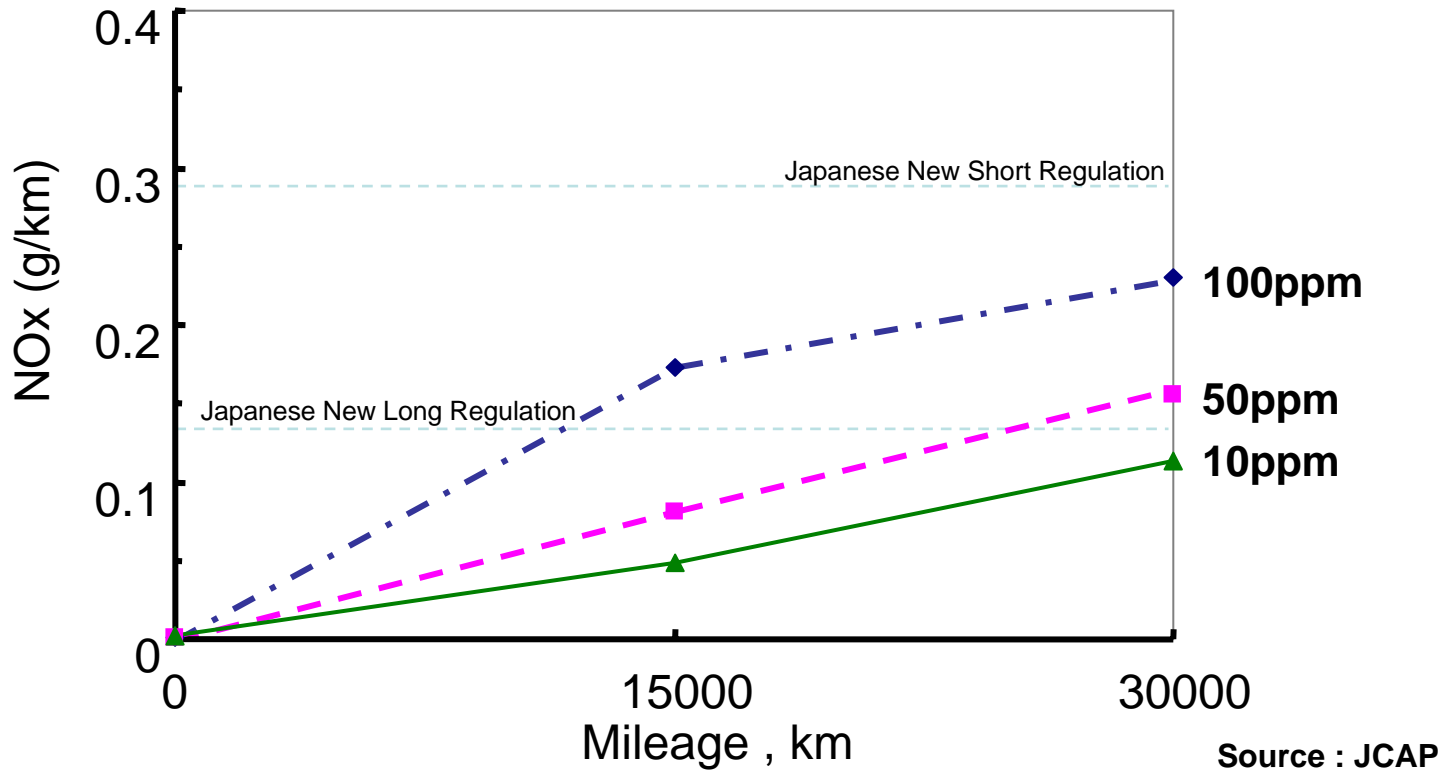

Fuel sulfur has a significant impact on NOx emissions from vehicles with NOx catalyst.

Effects of Sulfur on PM (CR-DPF System)

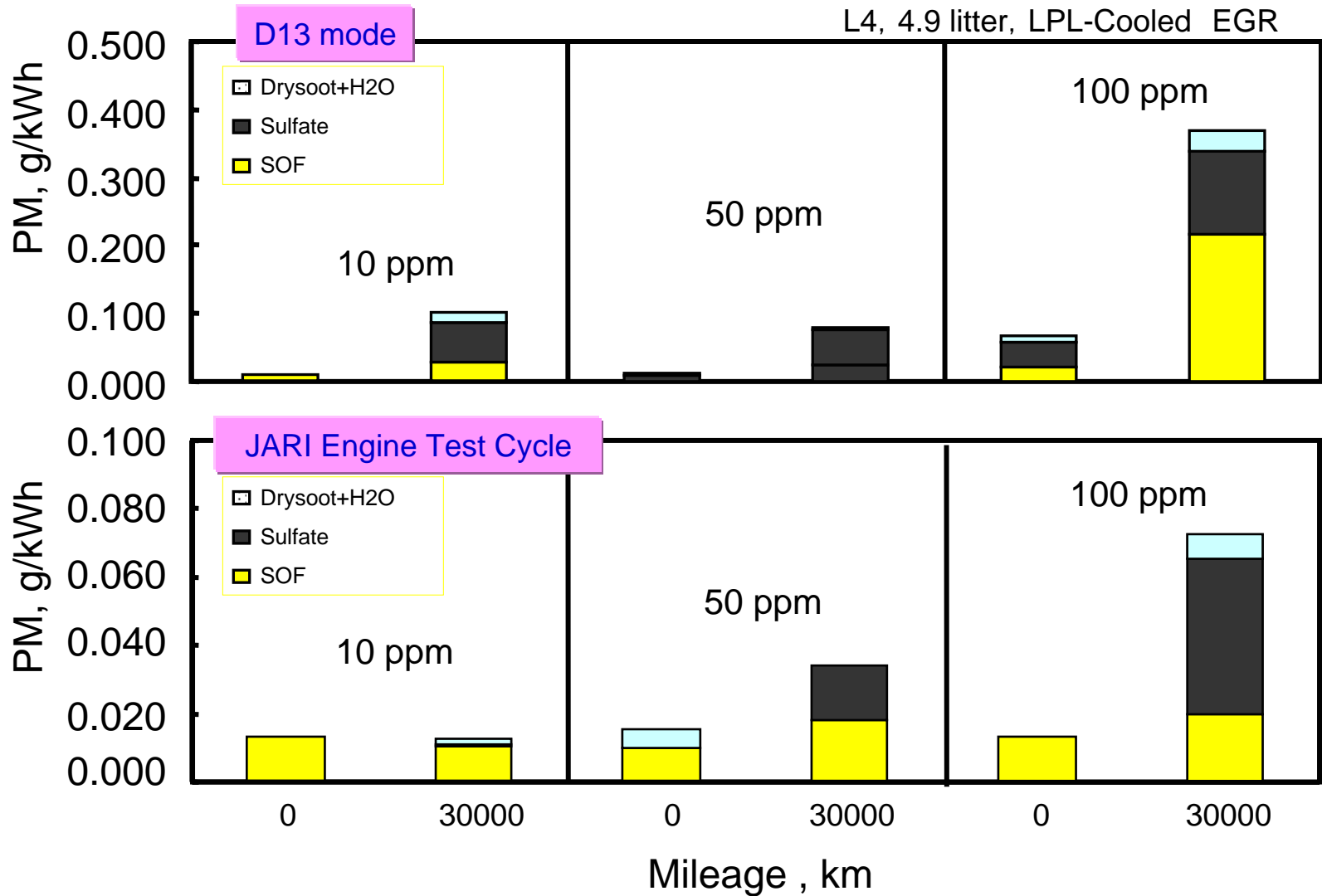

Effects of Fuel Properties on Emissions

Diesel Fuel

Properties \ Emissions	Smoke	CO	NOx	PM
T90 ↓	↘		↘	↘
Aromatics ↓	↘	↘	↘	↘
Poly Aromatics ↓				↘
Sulfur ↓				↘
Oxygenates ↑	↘			↘
CN ↑		↘	↘	↘
Density, Viscosity ↓	↘		↘	↘

Sulfur Reduction in Diesel Fuel

Emission control systems to be required for emission reduction are

- Euro2 EGR, Oxidation catalyst
- Euro3 Cooled EGR, Oxidation catalyst
- Euro4/5 Cooled EGR, DPF, DeNOx catalyst

When higher sulfur diesel fuel than the requirement used,

- Lowering engine durability significantly
- Reducing life of Aftertreatment system
- Deteriorating emission

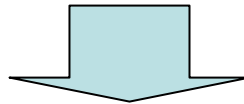

Lowering sulfur is essential to introduce lower emission technology for improving air.

Summary

- ✓ Fuel quality relates closely to emissions and vehicle performance.
- ✓ In order to achieve improving air quality, introducing quality fuel is important from the viewpoint of reducing emissions.

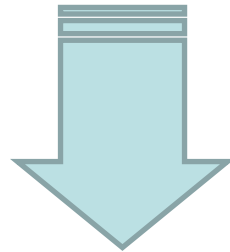

Sulfur:	Gasoline	Diesel fuel
	EU regulation	EU regulation
Euro2	500	500
Euro3	150	350
Euro4	50	50